

BXW-H Safety brakes - Datasheet

HOLDING AND BRAKING USE

Specifications

Model	Size	Static friction torque T_s [N·m]	Coil [at 20 °C]				Heat resistance class	Lead wire		Max. rotation speed [min ⁻¹]	Rotating part moment of inertia J [kg·m ²]	Allowable braking energy rate P_{ba} [W]	Total braking energy E_T [J]	Armature pull-in time t_a [s]	Armature release time t_r [s]	Mass [kg]
			Voltage [V]	Wattage [W]	Current [A]	Resistance [Ω]		UL style	Size							
BXW-01-10H	01	0.24	12	5.0	0.417	28.8	F	UL3398	AWG26	5000	0.6×10^{-6}	0.5	0.2×10^6	0.010	0.010	0.2
			24	5.0	0.208	115	F									
			45	5.0	0.111	405	F									
			90	5.0	0.056	1622	F									
			180	5.0	0.028	6486	F									
BXW-02-10H BXW-02-12H	02	0.50	12	6.6	0.550	21.8	F	UL3398	AWG26	5000	1.9×10^{-6}	1.0	0.3×10^6	0.010	0.010	0.3
			24	6.6	0.275	87.3	F									
			45	6.6	0.147	307	F									
			90	6.6	0.073	1228	F									
			180	6.6	0.037	4912	F									
BXW-03-10H BXW-03-12H	03	1.00	12	9.0	0.750	16.0	F	UL3398	AWG26	5000	3.8×10^{-6}	2.0	0.5×10^6	0.035	0.020	0.4
			24	9.0	0.375	64.0	F									
			45	8.2	0.182	247	F									
			90	8.2	0.091	988	F									
			180	8.2	0.046	3954	F									
BXW-04-10H BXW-04-12H	04	2.00	12	11.5	0.958	12.5	F	UL3398	AWG22	5000	12.0×10^{-6}	4.0	1.0×10^6	0.040	0.025	0.6
			24	11.5	0.479	50.1	F									
			45	10.0	0.222	203	F									
			90	10.0	0.111	810	F									
			180	10.0	0.056	3241	F									
BXW-05-10H BXW-05-12H	05	4.00	12	13.0	1.083	11.1	F	UL3398	AWG22	5000	23.0×10^{-6}	6.0	2.0×10^6	0.045	0.030	0.8
			24	13.0	0.542	44.3	F									
			45	13.0	0.289	156	F									
			90	13.0	0.144	623	F									
			180	13.0	0.072	2492	F									

* The armature pull-in time and armature release time are taken during DC switching.

Dimensions

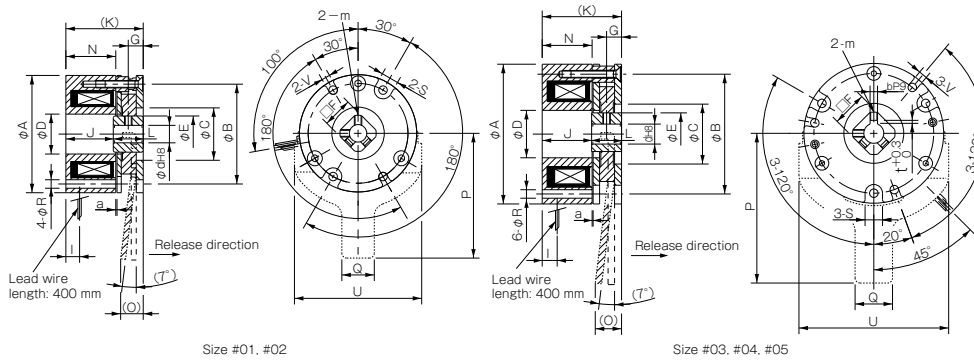

Size	Radial direction dimensions											Axial direction dimensions								Bore dimensions				
	A	B	C	D	E	S	V	R	F	m	O	P	Q	U	G	I	J	K	L	N	a	d	b	t
01	37	32	18	13.5	12.0	6	3	3	10	M3	-	-	-	-	4.5	5.0	22.5	31.5	9	22.5	0.10	5	-	-
02	47	40	21	16.0	14.5	7	3.4	3.4	12	M3	9	50	13	51	6.0	5.5	19.2	31.2	12	20.0	0.10	6	-	-
03	56	48	24	19.0	17.0	7	3.4	3.4	14	M3	11	60	15	60	6.0	6.0	19.9	31.9	12	20.0	0.15	8	-	-
04	65	58	35	24.0	22.0	7	3.4	3.4	18	M4	12	70	15	70	7.0	7.0	19.9	33.9	14	21.0	0.15	10	3	1.2
05	75	66	36	28.0	26.5	9	4.5	4.5	22	M4	14	80	20	80	7.0	7.0	22.1	36.1	14	21.5	0.15	12	4	1.5

* There is no release lever option for size #01.

How to Place an Order

BXW-01-10H-24V-5

Size: 01
 Release lever: 10 (Not included), 12 (Included)
 Bore diameter (dimensional symbol d): 5, 6, 7, 8, 10, 12
 Voltage (Specifications table): 12, 24, 45, 90, 180
 Application H: Holding-use

* Further bore diameters and voltages possible on request.



MIKI PULLEY EUROPE AG

www.mikipulley.de

Rheinweg 5, CH-8200 Schaffhausen, Tel: +41 52 625 24 24
Bauhofstraße 12, D-63762 Großostheim, Tel: +49 6026 999 610



ammertech
moving forward

Grasbeemd 21,
5705 DE Helmond, Nederland
Tel. +31 (0)492 594 300,

E-mail: pr@ammertech.nl,
Internet: www.ammertech.nl