

# BXL Safety brakes - Datasheet

## Specifications

Model	Size	Static friction torque TS [N-m]	Coil [at 20 °C]				Heat resistance class	Lead wire		Max. rotation speed [min <sup>-1</sup> ]	Rotating part moment of inertia J [kg-m <sup>2</sup> ]	Allowable braking energy rate P <sub>ba2</sub> [W]	Total braking energy E <sub>t</sub> [J]	Armature pull-in time t <sub>a</sub> [s]	Armature release time t <sub>ar</sub> [s]	Mass [kg]
			Voltage [V]	Wattage [W]	Current [A]	Resistance [Ω]		UL style	Size							
BXL-06-10	06	2	DC24	15	0.63	38.4	F	UL3398	AWG22	5000	3.75 × 10 <sup>-5</sup>	58.3	2.0 × 10 <sup>7</sup>	0.035	0.020	0.9
			DC45	12	0.27	169										
			DC90	12	0.13	677										
BXL-08-10	08	4	DC24	22.5	0.94	25.6	F	UL3398	AWG18	5000	6.25 × 10 <sup>-5</sup>	91.7	3.5 × 10 <sup>7</sup>	0.040	0.020	1.3
			DC45	19	0.41	110										
			DC90	19	0.21	440										
BXL-10-10	10	8	DC24	28	1.14	21.1	F	UL3398	AWG18	4000	13.75 × 10 <sup>-5</sup>	108.3	6.2 × 10 <sup>7</sup>	0.050	0.025	2.3
			DC45	25	0.54	83.0										
			DC90	25	0.27	331										
BXL-12-10	12	16	DC24	35	1.46	16.2	F	UL3398	AWG18	3600	33.75 × 10 <sup>-5</sup>	133.3	9.0 × 10 <sup>7</sup>	0.070	0.030	3.4
			DC90	30	0.33	271										
BXL-16-10	16	22	DC24	39	1.64	14.6	F	UL3398	AWG18	3000	7.35 × 10 <sup>-4</sup>	183.3	11.4 × 10 <sup>7</sup>	0.100	0.035	5.4
			DC90	39	0.43	207										

\* The armature pull-in time and armature release time are taken during DC switching.

## Dimensions

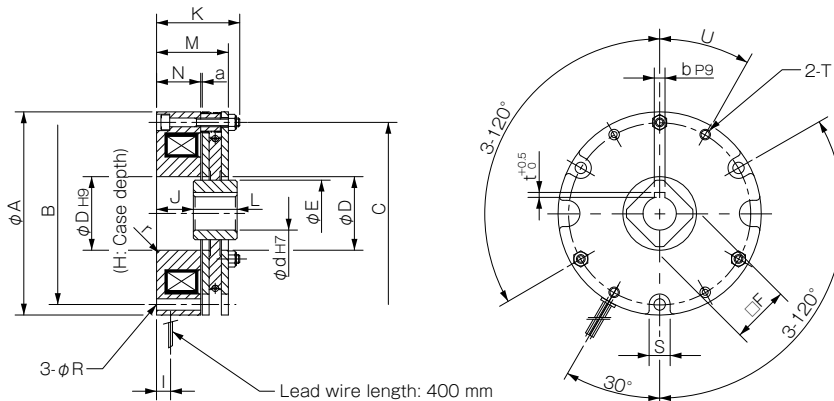

Size	A	B	C	r	D	E	F	H	I	J	K	L	M	N	R	S	T	U	a	d	b	t
06	83	73	73	R1	28	26.5	22	3	10	20.5	39.5	14	33.6	20	4.5	9	2-M5	30°	0.15	11	4	1.5
08	96	86	86	R1	35	32	25	3	12	20	41	17	35	20.8	5.5	10.5	2-M5	30°	0.15	14	5	2
10	116	104	104	R1	42	38	30	3	9.5	21	47.5	25	41	25.3	6.5	12.5	2-M6	30°	0.2	19	6	2.5
12	138	124	124	R1	50	45	35	4	12	19	49.8	30	43.5	23.3	6.5	12.5	2-M6	30°	0.2	24	8	3
16	158	142	143	R1	59	55	45	4	14	22.5	57.5	35	51	27.7	9	15.0	2-M8	40°	0.25	28	8	3

Unit [mm]

How to Place an Order

BXL-06-10G 24V 11DIN

Size ——— Bore diameter (dimensional symbol d)  
 Option number ——— Voltage (Specifications table)  
 10: Standard

\* Further bore diameters and voltages possible on request.



**Options**

Made to Order

**Release Lever**

**Option No.: 12**

We also offer an option with a manual release lever. See the dimensions table below for the dimensions of brakes with release levers. Please contact Miki Pulley for other specification values.

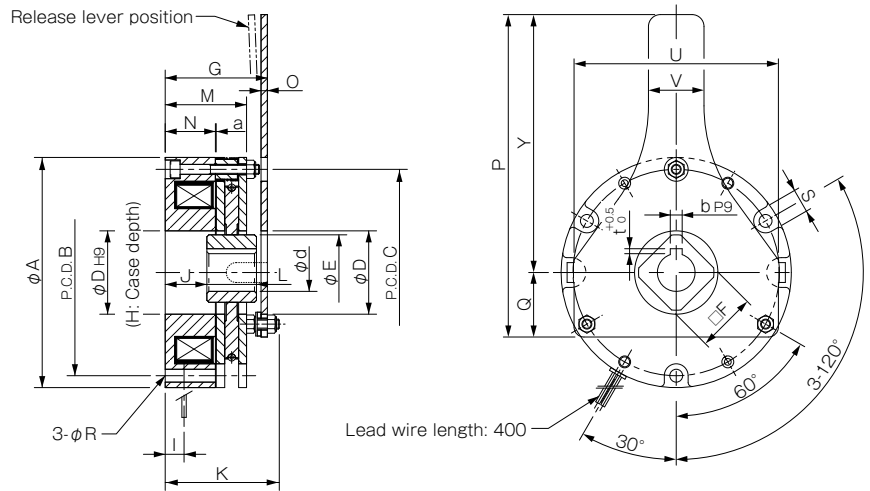

Model	A	B	C	D	E	F	G	H	I	J	K	L	M	N	O	P	Q	R	Y	U	V	S	a	d	b	t
BXL-06-12	83	73	73	28	26.5	22	42.4	3	10	20.5	49.5	14	33.7	20	2.6	88	24	4.5	64	73	16	9	0.15	11	4	1.5
BXL-08-12	96	86	86	35	32	25	44	3	12	20	51	17	35	20.8	2.9	122	27	5.5	95	85	20	10.5	0.15	14	5	2
BXL-10-12	116	104	104	42	38	30	51.2	3	9.5	21	57.5	25	41	25.3	3.2	162.5	32.5	6.5	130	103	28	12.5	0.2	19	6	2.5
BXL-12-12	138	124	124	50	45	35	56.4	4	12	19	64.8	30	43.5	23.3	5	200	40	6.5	160	121	36	12.5	0.2	24	8	3
BXL-16-12	158	142	143	59	55	45	64.9	4	14	22.5	72.5	35	51	27.7	6	300	44	9	186	140	36	15.5	0.25	28	8	3

**Quiet Mechanism (Silencing Spring)**

**Option No.: S1**

There is a extremely small structural backlash (see figure on the right) between the rotor and the rotor hub. In applications that are prone to microvibrations of the drive shaft such as single-phase motors, this backlash may produce rattling (banging). The silencing spring for the rotor hub reduces this rattling.

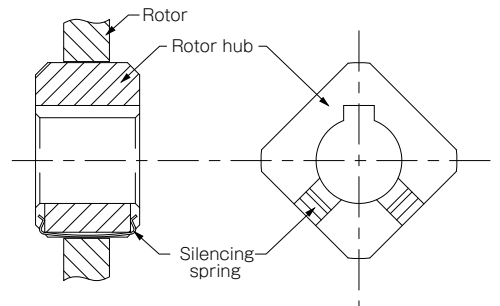

**Quiet Mechanism (Pull-in Noise Reduction Mechanism)**

**Option No.: S2**

When the brake is energized, a magnetic circuit is formed, and the armature is pulled to the stator by that magnetic force. At that time, the armature touches the magnetic pole of the stator and a noise is produced. This sound (pull-in noise) is reduced by putting shock absorbing material in the stator's magnetic pole part. In option S2, in addition to the pull-in noise reduction mechanism, the silencing spring (option S1) is also supplemented.

**List of Option Numbers**

Description of options	No quiet mechanism	Silencing spring	Silencing spring + Pull-in noise reduction mechanism
No release lever	10	10S1	10S2
With release lever	12	12S1	12S2

• Option 10 uses standard specifications.

**BXL-06-12S1G 24V 11DIN**

