

ETP-TECHNO®

High precision and frequent mounting

ETP-TECHNO is a hydraulic connection with very high precision. It is especially designed for applications where fast frequent changes or adjustments, with high precision are needed. It can be mounted/dismantled 1000's of times.

ETP-TECHNO is very easy to mount with only one screw, and it also has extremely good concentricity.

ETP-TECHNO is the one to choose among the ETP hub-shaft connections when very high precision is needed.



Precision adjustment

In this machine for scraping aluminium bands, the spiral knives have to be set accurately in relation to each other and need to be changed quickly, when worn out. This and the good runout and compact design was the reason for the choice of ETP-TECHNO, for fastening the gears on the cutting wheel shaft.



Frequent changes

In a test rig for vehicle gearboxes the output shaft is connected to a torque limiter with ETP-TECHNO to control the torque transmission. Many gearboxes are tested so the changes have to be done quickly. No backlash and radial access to the screw are also important.



Overload protection

ETP-TECHNO fastens the boring equipment in the front of this mobile boring machine. ETP-TECHNO do not rotate. If the boring equipment is subject to an overload it should not get damaged, ETP-TECHNO then slips instead, (part of a turn). The tolerance for the shaft and the tightening torque for the screw, have been calculated to limit the torque. The shaft surface and ETP-TECHNO are not damaged in this limited slippage. The boring equipment is repositioned, the screw is tightened easily and quickly.



Good runout, moderate surface pressure

A gear of a special soft fibre material is fastened with ETP-TECHNO in special design for operating this printing machine. The moderate and even surface pressure from ETP-TECHNO makes sure that the expansion of the gear is limited. The hydraulic principle creates a good runout, small unbalance and thus a low noise level.



Radial tightening of one screw, good runout

When this gear, built into a drive line for a printing machine, is fixed there is no access in the axial direction. A bore has been machined through the black flange, through which it is possible to tighten the screw radially. The runout is important to get the precision in the gear drive and a minimum of backlash.



Low moment of inertia, quick changes

The coupling is used in a test bench for testing of gearboxes. ETP-TECHNO means that change of gearbox can be done quickly. The small built-in dimensions and the low weight for ETP-TECHNO, creates a minimum of moment of inertia. Also the good runout is important to minimise the unbalance.

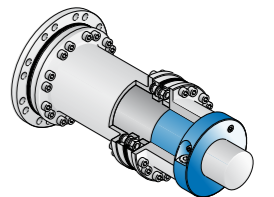

Good runout, frequent mounting

The speeds are often high and mounting is done frequently in this machine for measuring torque. The torque transmission is tested for example for motors and gearboxes. Fastening of the drive shaft is done with ETP-TECHNO of various sizes. The changes are done quickly and the fastening is very accurate.

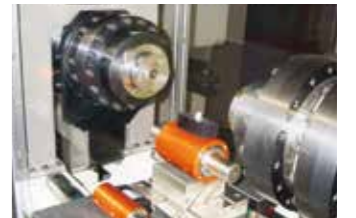

Good runout, quick tool change

A larger number of ETP-TECHNO in a special design, fasten the tooling in this punching machine. The good runout which is repeatable even after many changes is important. To minimize the downtime for tool change it is beneficial to have only one screw per connection. The radial access gives a compact design.





High precision

ETP-TECHNO is a hydraulic connection for high precision and frequent mounting. Available as standard for shafts 15 - 130 mm, also imperial. Runout $\leq 0,006$ mm.

Number of mountings 500 - 5 000 (size dependent). It has an extra seal consisting of a steel ball at the end of the piston, which is pressed against a spherical seating when mounted. ETP-TECHNO is often used as a base for special and customised solutions.

Construction

ETP-TECHNO is a hydraulic connection which consists of a double-walled hardened steel sleeve filled with a pressure medium, and a flange. The flange contains the pressure screw and piston with dual sealing function - an o-ring plus backup ring and a steel ball.

Operation

When the pressure screw is tightened, the double-walled sleeve expands uniformly against the shaft and the hub and creates a rigid joint. Dismantling of the joint is simply done by loosening the screw. ETP-TECHNO returns to its original measurements and can easily be dismantled.

When the pressure screw is tightened to the recommended tightening torque, T_t , the steel ball seals against the spherical seating. ETP-TECHNO will create a uniform surface pressure against the shaft and hub.

Benefits and features

- Extremely fast mounting/dismantling with only ONE screw.
- Can be mounted/dismantled 1000's of times.
- Extremely good concentricity, ≤ 0.006 mm, also after several mountings.
- Dual sealing system.
- Radial tightening of the screw saves space along the shaft.
- Small built-in dimensions.
- Accurate positioning, no axial movement when mounting.

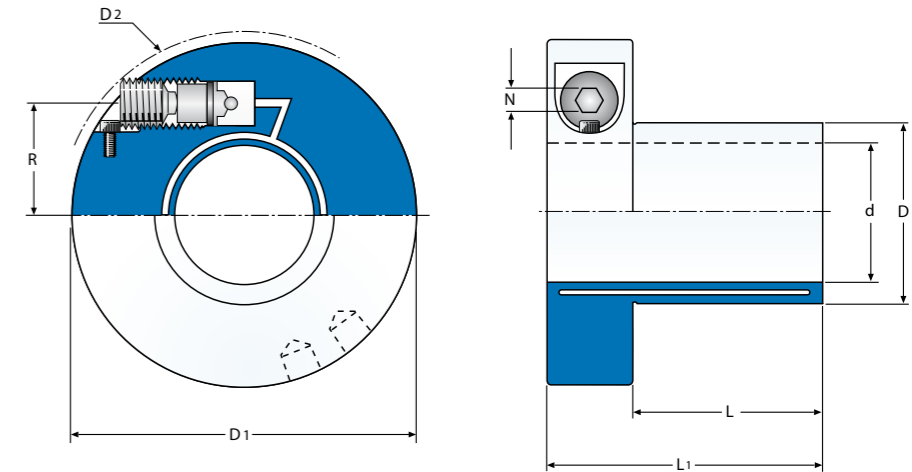
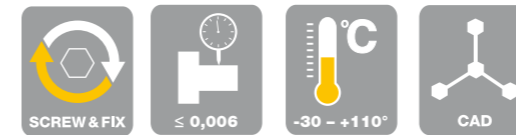
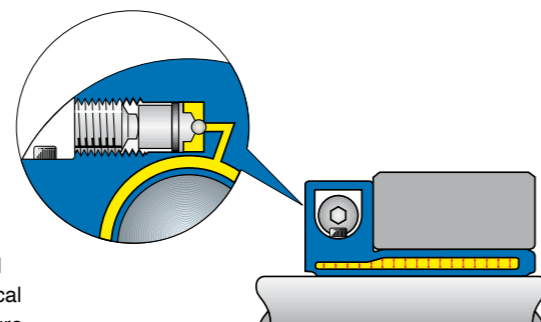

Notation: ETP-TECHNO XXX

Technical specification ETP-TECHNO®

| ETP-TECHNO® | Dimensions | | | | | | Transmittable | | | Screws | | | | Polar moment of inertia J $\text{kgm}^2 \cdot 10^{-3}$ | Weight kg |
|-------------|------------|------|-------------------|---------------------|------|-------------------|---------------|-------------------|-------------------|-----------|------|------|-------------------|--|-----------|
| | d mm | D mm | D ₁ mm | D ₂ * mm | L mm | L ₁ mm | T Nm | F _A kN | F _R kN | Dim. | R mm | N mm | T _t Nm | | |
| 15 | 15 | 19 | 52 | 54 | 25 | 41 | 50 | 5 | 1 | M12 | 16 | 6 | 10 | 0,09 | 0,25 |
| 20 | 20 | 25 | 59 | 61 | 30 | 46 | 145 | 12 | 2 | M12 | 19 | 6 | 10 | 0,15 | 0,32 |
| 25 | 25 | 32 | 70 | 72 | 35 | 55 | 250 | 16 | 3 | M14 | 24 | 6 | 16 | 0,38 | 0,58 |
| 1" | 25,4 | 32 | 70 | 72 | 35 | 55 | 250 | 16 | 3 | M14 | 24 | 6 | 16 | 0,38 | 0,58 |
| 30 | 30 | 38 | 75 | 79 | 40 | 60 | 500 | 26 | 4 | M14 | 25,5 | 6 | 16 | 0,54 | 0,69 |
| 1 1/4" | 31,75 | 41 | 79 | 83 | 42 | 62 | 510 | 25 | 4 | M14 | 27,5 | 6 | 16 | 0,64 | 0,78 |
| 32 | 32 | 41 | 79 | 83 | 42 | 62 | 510 | 25 | 4 | M14 | 27,5 | 6 | 16 | 0,64 | 0,78 |
| 35 | 35 | 44 | 84 | 90 | 45 | 65 | 740 | 34 | 5 | M16 | 29,2 | 8 | 24 | 0,75 | 0,84 |
| 1 1/2" | 38,1 | 50 | 90 | 95 | 50 | 70 | 880 | 36 | 5 | M16 | 32,5 | 8 | 24 | 1,1 | 1,08 |
| 40 | 40 | 52 | 91 | 98 | 55 | 75 | 1200 | 47 | 6 | M16 | 32,7 | 8 | 24 | 1,3 | 1,18 |
| 45 | 45 | 56 | 96 | 105 | 58 | 78 | 1700 | 62 | 7 | M16 | 34,7 | 8 | 24 | 1,5 | 1,24 |
| 50 | 50 | 65 | 110 | 117 | 60 | 85 | 2250 | 71 | 9 | M20 | 40,5 | 10 | 40 | 2,3 | 1,64 |
| 60 | 60 | 75 | 125 | 154 | 70 | 95 | 4400 | 119 | 12 | M20 | 46,3 | 10 | 40 | 5 | 2,51 |
| 70 | 70 | 90 | 140 | 156 | 85 | 110 | 7000 | 158 | 13 | M20 | 53 | 10 | 40 | 8,9 | 3,65 |
| 75 | 75 | 95 | 148 | 164 | 90 | 115 | 8600 | 183 | 14 | M20 | 55,3 | 10 | 40 | 12 | 4,20 |
| 80 | 80 | 100 | 156 | 173 | 95 | 123 | 10900 | 218 | 15 | M22 | 58,7 | 10 | 60 | 15 | 4,85 |
| 90 | 90 | 112 | 166 | 180 | 105 | 133 | 15500 | 277 | 17 | 2 x M22** | 63,3 | 10 | 60 | 22 | 5,44 |
| 100 | 100 | 125 | 177 | 192 | 115 | 143 | 21000 | 335 | 19 | 2 x M22** | 69,6 | 10 | 60 | 33 | 6,18 |
| 110 | 110 | 138 | 187 | 202 | 125 | 153 | 28000 | 410 | 21 | 2 x M22** | 75,1 | 10 | 60 | 43 | 7,08 |
| 120 | 120 | 150 | 198 | 217 | 135 | 163 | 29000 | 393 | 23 | 2 x M22** | 80,9 | 10 | 50 | 54 | 9,96 |
| 130 | 130 | 163 | 208 | 226 | 135 | 163 | 32000 | 393 | 25 | 2 x M22** | 86,3 | 10 | 46 | 75 | 10,86 |

T= Transmittable torque when axial force is 0. } When the screw/screws is tightened to T_t .
 F_A=Transmittable axial force when torque is 0.
 F_R=Max transmittable radial force at continuous operation.
 Max allowed bending torque: 10% of transmittable torque T.
 T_t= Recommended tightening torque for the screw/screws. Further tightening does not increase the pressure.
 *) D2 is valid before mounting.
 **) Pressure screws positioned in the same direction. Dimensions subject to alterations without notice.

Tolerances
 Shaft h8.
 Hub H7.

Type of torque
 Transmittable torque, T, is for static load.
 If the load is alternating or pulsating torque, reduce the transmittable torque, T, with the following factors: (factor x T).
 Alternating: 0,7 x T.
 Pulsating: 0,8 x T.

For further information see section Technical information/ Design tips, page 52-55.





Grasbeemd 21, 5705 DE Helmond, Nederland
Tel. +31 (0)492 594 300,
E-mail: pr@ammertech.nl, Internet: www.ammertech.nl



Box 1120, SE-581 11 Linköping, Sweden
Tel. +46 (0)13 24 71 00, Fax +46 (0)13 24 71 90
E-mail: info@etp.se, Internet: www.etp.se