

ETP-HYLOC®

For heavy loads and quick mounting

ETP-HYLOC is a hydro-mechanical hub-shaft connection which, due to its robust design, is ideally suited to work in difficult environments and heavy operations like steel rolling mills, process industries etc. An interesting application, among many, has been fastening of feeding or forming rolls to shafts. ETP-HYLOC is fast to mount, has good concentricity and can take high torque and radial loads. Mounting and dismantling is easily carried out with a hydraulic pump.



Good runout, easy to position

In this straightening line for steel, the forming rollers are fastened with ETP-HYLOC. The position of the rollers relatively to each other along the shafts are exactly adjusted, it will not change during pressurising. The radial runout is minimised and the change of rollers facilitated. High radial forces can be transmitted with ETP-HYLOC, as the connection is solid all through.



Good runout, simple to adjust

ETP-HYLOC, due to its robust design, is suited for difficult environments and heavy operations. Here the feed rollers are fastened in a steel mill. Adjustment of the rollers is easy to do and with high precision. When in operation the good runout is important. When the rollers need to be changed the quick dismantling is valuable to decrease down time.



Good runout, thin hub

Fastening and centering of a turbine runner puts high requirements on the connection. Often a relatively soft material is used in the hub, which should be subject to a limited tension. The moderate and even surface pressure from ETP-HYLOC works well also with thin walled hubs. The high speeds require good runout. Mounting and adjusting is made easy and fast due to the easy pressure setting.



High torque, no backlash

The gear for operating a machine for production of pet food is fastened with ETP-HYLOC. Important at the selection was the accurate adjustment to avoid backlash, the possibility to take up high peak loads at emergency stops, as well as the easy and quick mounting.



High radial force, quick changes

Centering and fastening of the feed rollers in a processing line for steel working. ETP-HYLOC centres the rollers, take up and transfers the high and irregular radial forces to the shaft. Adjustments to change worn out rollers and change to other profiles are done with a minimum of downtime, with the help of only a hydraulic handpump.



Precision fastening, quick adjustment

Fastening of the measuring shaft and the part which will be subject to a torque, in this torque test rig in the automobile industry, are both done with ETP-HYLOC. Precision, no backlash, limited surface pressure that does not damage the surfaces and quick change of parts to be tested are important factors.



High axial forces, simple adjustment

In this test equipment, volcano rock samples are subject to compression tests under high temperature. ETP-HYLOC fasten the top reaction plate to the vertical shafts and take up the high axial forces. When adjusting for a new sample, the reaction plate is raised and lowered again, the connections can be easily loosened and set again.



Accurate positioning, dynamic loads

Four chop and trimming shears in this machine, which belongs to a processing line for steel, must be accurately synchronised. On each wheel there are a number of knives, which trim front and back end coils which passes through. ETP-HYLOC centres and fastens the wheels. The knives are synchronised along and around the shafts and maintain their accurate positions during pressurising. The uneven dynamic loads in the radial direction are transferred through ETP-HYLOC.



Heavy loads and quick mounting



ETP-HYLOC is available as standard for shafts 50 - 220 mm. Runout $\leq 0,02$ mm. Number of mountings: Max. 2 000. Customized models for shaft > 220 mm can also be offered on request.

For extreme high torque applications the contact surfaces of ETP-HYLOC (sizes ≥ 100 mm) can be plated with ETP-HFC, High Friction Coating, which doubles the torque capacity.

Construction

ETP-HYLOC is a hydro-mechanical joint, which consists of a double-walled steel sleeve which encloses a conical moveable piston. Mounting and dismantling is carried out with a hydraulic pump. In the flange there are three threaded connections ("ON", "P" and "OFF") in the radial direction and the same in the axial. This makes it possible to choose radial or axial connection of the pump hoses, depending on the build-in situation.

Operation

When the piston is moved, by the hydraulic pressure from the pump, the double-walled sleeve expands uniformly against shaft and hub to form a rigid joint. When dismantling, the piston is moved in the opposite direction and the joint will loosen. A small amount of oil will be taken via spiral tracks in the piston between the surfaces (pressure applied through the "P" connection), in this way making it easier for the piston to move. Normal working pressure is 1 000 bar.

Benefits and features

- High transmittable torque capacity - can be varied by changing the mounting pressure.
- Fast mounting/dismantling in tight spaces.
- High radial load capacity.
- Radial and axial connection is possible.
- Fine adjustments of the hub can be made when mounting.
- Good concentricity, also after several mountings.
- With ETP-HFC coating – double torque capacity.

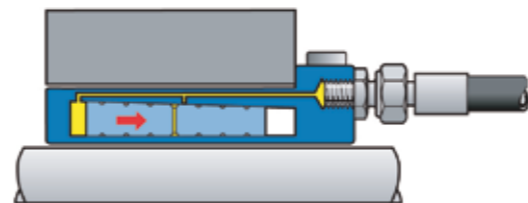

Mounting: apply pressure in the "ON" and "P" (not shown) connections. When mounted no hydraulic pressure remains. The small conical angle prevents the piston from releasing.

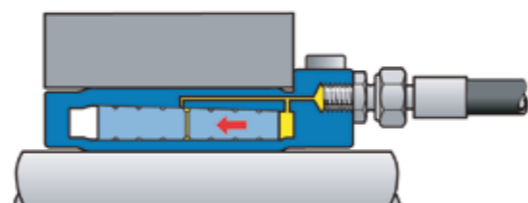

Dismantling: apply pressure in the "OFF" and "P" (not shown) connections. ETP-HYLOC returns to its original measurements and the joint is loose.

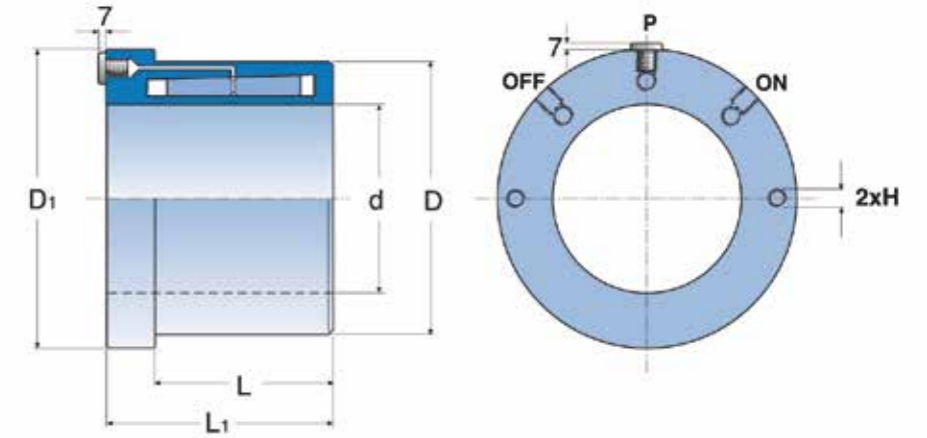

Notation: ETP-HYLOC XXX

Technical specification ETP-HYLOC®

ETP-HYLOC®	Dimensions					Transmittable torque or axial force at 1000 bar						H	Polar moment of inertia J kgm ² · 10 ⁻³	Weight kg
	d mm	D mm	D ₁ mm	L mm	L ₁ mm	Shaft h7		Shaft h8		Min hub D _H mm				
						T kNm	F _A kN	T kNm	F _A kN	Yieldpoint N/mm ² >300	Yieldpoint N/mm ² >400			
50	50	77	101	56	82	2,6	70	2,4	70	110	105	M8	3,2	2,4
60	60	89	113	64	90	4,6	130	4,3	130	140	125	M8	5,4	3,1
70	70	102	122	74	100	7,9	210	7,4	200	170	145	M8	8,7	4,1
80	80	115	135	84	110	12,1	290	11,5	280	200	160	M8	14	5,4
90	90	128	148	94	120	17,1	380	16,2	360	235	180	M12	23	7,0
100	100	140	160	104	130	24,2	485	23,1	460	270	200	M12	34	8,6
110	110	154	173	114	140	32,9	595	31,5	570	295	220	M12	51	11
120	120	168	186	124	150	43,2	720	41,6	690	320	240	M12	76	14
130	130	182	200	134	160	53,8	825	51,4	790	350	260	M16	110	17
140	140	196	213	144	170	68,9	985	66,2	945	375	280	M16	150	21
150	150	210	227	154	180	85,4	1135	82,3	1095	400	300	M16	210	25
160	160	224	240	164	190	104	1305	100	1260	425	320	M16	290	30
180	180	252	267	184	210	150	1675	146	1625	480	360	M16	500	42
200	200	280	293	204	230	206	2060	200	2000	535	400	M16	830	56
220	220	308	320	224	250	273	2485	266	2415	585	435	M16	1300	73

T = transmittable torque when axial force is 0.
 F_A = transmittable axial force when torque is 0.
 D_H = Outer diameter for hub material in steel.
 H: Threads for easy handling. Dimension subject to alterations without notice.

ETP-HYLOC®	600 bar				800 bar				1200 bar				
	Shaft h7		Min. hub D _H		Shaft h7		Min. hub D _H		Shaft h7		Min. hub D _H		
	T kNm	T kNm	Yieldpoint N/mm ² >200	Yieldpoint N/mm ² >300	Yieldpoint N/mm ² >400	T kNm	T kNm	Yieldpoint N/mm ² >300	Yieldpoint N/mm ² >400	T kNm	T kNm	Yieldpoint N/mm ² >300	Yieldpoint N/mm ² >400
50	0,8	0,8	90	90	90	1,6	1,4	95	90	3,3	3,1	130	
60	1,1	1,1	115	105	95	3,3	3	120	110	5,9	5,6	155	
70	2,4	2,4	135	120	110	5,8	5,3	140	125	9,9	9,5	170	
80	5,6	5,3	155	140	130	9	8,4	165	140	15,3	14,6	190	
90	8,3	7,4	180	160	145	12,7	11,8	185	160	21,6	20,6	215	
100	12,1	11	200	170	160	18,2	17,1	210	180	30,3	29,2	235	
110	16,8	15,4	220	195	180	24,8	23,5	235	195	41	39,6	260	
120	22,3	20,6	240	215	195	32,7	31,1	255	215	53,7	52	280	
130	27,2	24,9	260	230	210	40,5	38,1	275	230	67	64,7	305	
140	35,6	32,9	285	250	225	52,3	49,6	295	250	85,6	82,9	325	
150	44,5	41,4	300	265	240	65	61,9	315	265	105	102	350	
160	54,8	51,2	320	285	260	79,5	76	335	285	129	125	370	
180	80	75	360	320	290	115	110	375	320	186	181	415	
200	109	103	400	355	320	157	151	420	355	254	248	465	
220	144	137	440	390	355	209	201	460	390	338	330	510	

Transmittable torque at different mounting pressures. The torque for sizes ≥ 100 can be increased by using ETP-HFC®

TOLERANCES
 Shaft h7 or h8
 Hub H7

MOUNTING – ADVICE The contact surfaces L and L₁ must be completely covered by the shaft and hub. The oil for the pump should be a transmission oil type 80 W. For other hub materials, for example aluminium, contact us.

MOUNTING PRESSURE The mounting pressure is normally 1000 bar. Max mounting pressure 1200 bar. Dismantling requires approx. 200 bar higher pressure than for mounting.

ETP-HYLOC can be designed to suit special applications on request, and also larger sizes are available.

For further information see section Technical information/Design tips, page 52-55.





Grasbeemd 21, 5705 DE Helmond, Nederland
Tel. +31 (0)492 594 300,
E-mail: pr@ammertech.nl, Internet: www.ammertech.nl



Box 1120, SE-581 11 Linköping, Sweden
Tel. +46 (0)13 24 71 00, Fax +46 (0)13 24 71 90
E-mail: info@etp.se, Internet: www.etp.se