

ETP-EXPRESS[®]

For fast mounting and compact design

ETP-EXPRESS is a hydraulic connection which has only one screw for pressurising. It is especially suitable for repositioning of the hub fast and accurately. The screw is tightened in the radial direction, this means no space is used along the shaft for mounting tools. Other components can be mounted on the shaft all the way up to the flange. ETP-EXPRESS has extremely small built-in dimensions which makes a compact design possible.



Easy to position and adjust with one screw

In this handling and packaging machine for newspapers after printing, ETP-EXPRESS of various sizes are used. The final adjustment of levers and timing pulleys in order to get all parts synchronised is facilitated, as only one screw needs to be loosened/tightened. The radial access to the screw permits a compact design. Also hubs of aluminium and cast iron can be used because of the moderate surface pressure.

**Good runout and radial accessibility**

This unit belongs to a production line which inserts enclosures into newspapers after printing and folding. A number of star-shaped sorting wheels are fastened after each other along the shaft with ETP-EXPRESS. Tightening with radial access was a necessity for this compact design. Other requirements were good runout, low axial concentricity and a minimum of vibration.

**Thin hub**

The shaft for the timing drive in this packaging machine is relatively large, but the outer diameter for the timing pulley must be kept to a minimum. ETP-EXPRESS was chosen because of its small outer diameter and moderate surface pressure. The radial tightening also saved space along the shaft.

**Axial positioning along the shaft and low tightening torque**

Previously a universal joint with splines was used in a test bench, which caused backlash and vibrations. After the change to a disc coupling with integrated ETP-EXPRESS these problems were solved, at the same time the total length of the coupling can easily and quickly be adjusted. With frequent adjustment having a single screw with low tightening torque is a great help.

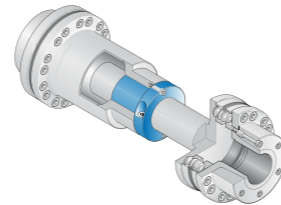
**Adjustability with only one screw**

For these two synchronized chain drives in this spring making machine, ETP-EXPRESS is used for fastening of the pulleys. The chains wear at different rates and need regular adjustment that can be done quickly. The single radially accessible screw makes this easy.

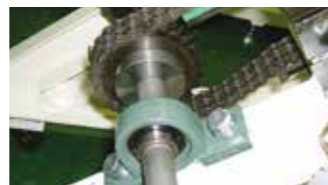
**No axial movement**

Before each press operation an accurate position needs to be established. ETP-EXPRESS is used as the position along the shaft will not change when pressurised, the sleeves are tensioned only in the radial direction into contact with shaft and hub. The radial access was another necessity for this design.

**Shorter assembly times**

In a production line for PET bottles, ETP-EXPRESS is used to fix without backlash a torque limiter. If the limiter should slip unintentionally it will lead to downtime. During assembly the whole machine is pretensioned for no backlash. In this setting the whole unit is locked by tightening of only one screw. This "one screw principle" saves operator time during assembly, which leads to increased productivity.

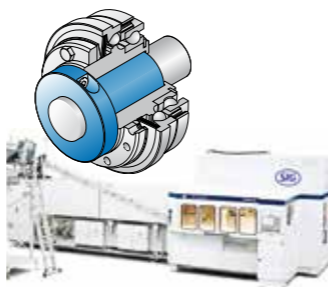
**Backlash free**

This metal disc coupling sits in a drive for a paper machine. Instead of a keyway ETP-EXPRESS is used, consequently the problems with backlash and fretting corrosion have been eliminated and the mounting made easier.

**Radial tightening**

When fastening the drive wheels for a number of synchronised transport chains, often the space along the shaft is limited. In this case it was solved with ETP-EXPRESS, as only radial access to the screw is needed. Only one screw per connection makes necessary adjustments after assembly easier.

**Synchronisation**

In transport equipment often a number of drives needs to be synchronised. In this machine ETP-EXPRESS is used for this purpose for both the chain and timing pulley drives. The simple mounting and radial access were the reasons. The compact built-in dimensions are also important for the timing pulleys.

**Quick changes/adjustments**

In this feeding mechanism for a steel plate punching machine several ETP-EXPRESS are used. The easy pressure setting of ETP-EXPRESS makes the change over to another size steel plate quick and accurate.

**Exact and reliable positioning/adjustment**

In friction welding of aluminium profiles a number of welding surfaces are pressed together under precise conditions. The locking levers fastened with ETP-EXPRESS perform this task. When adjusting to other profiles, a large number of levers have to be loosened, repositioned and accurately fixed again. The use of ETP-EXPRESS has reduced the downtime to a minimum. The radial tightening allows for a compact design.

**Quick changes**

These feeding rollers are fastened at both ends with ETP-EXPRESS, which needs a minimum of space along the shaft and facilitates dismantling/mounting for service and maintenance.

**Backlash free**

For this press ETP-EXPRESS was chosen for fastening the levers which steer the accurate feeding mechanism. No backlash and good repeatability were the important criteria when selecting the connection. The adjustment during assembly of the machine was at the same time made easier.

**Exact positioning**

During airplane assembly, a number of flexible fixtures, are used to support the fuselage. The fixture, can through the six arm design (hexa pod), be adjusted into any position required. ETP-EXPRESS, fastens each arm. This enables a completely stepless and precise length adjustment and positioning of the fixture. As no axial displacement occurs, the adjusted position will be maintained with needed precision for the fuselage assembly.

**Easy adjustment**

In this flow pack type packaging machine ETP-EXPRESS fastens a number of timing pulleys mounted on the drives. The radial tightening allows for a compact design and easy synchronisation and adjustment.

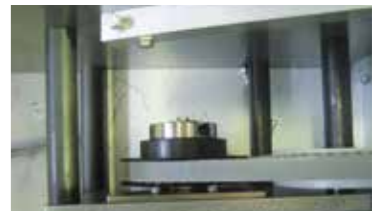
**Quick mounting**

In this digital printer sub system, for improving paper quality before printing, ETP-EXPRESS was chosen for its quick mounting and space saving features. The small built-in dimensions gives a compact and optimised design.



For fast mounting



ETP-EXPRESS is available as standard for shafts 15-100 mm, also imperial. Runout $\leq 0,02$ mm. Number of mountings 500 - 2 000 (size dependent). The extremely thin built-in dimensions allows for a compact design with low weight and inertia.

Construction

ETP-EXPRESS is a hydraulic connection which consists of a double-walled hardened steel sleeve filled with a pressure medium and a flange. The flange part contains screw and piston with seals to maintain pressure.

Operation

When the pressure screw is tightened, the double-walled sleeve expands uniformly against shaft and hub and creates a rigid joint. Dismantling is done by loosening the screw. ETP-EXPRESS returns to its original dimensions and can easily be dismantled.

When the pressure screw is tightened to the recommended tightening torque, the piston has reached the bottom of the bore. ETP-EXPRESS has created a uniform surface pressure against the shaft and hub.

Benefits and features

- Extremely fast mounting/dismantling with only ONE screw.
- Extremely small built-in dimensions.
- Radial tightening of the screw saves space along the shaft.
- Accurate positioning, no axial movement when mounting.
- Good concentricity, also after several mountings.

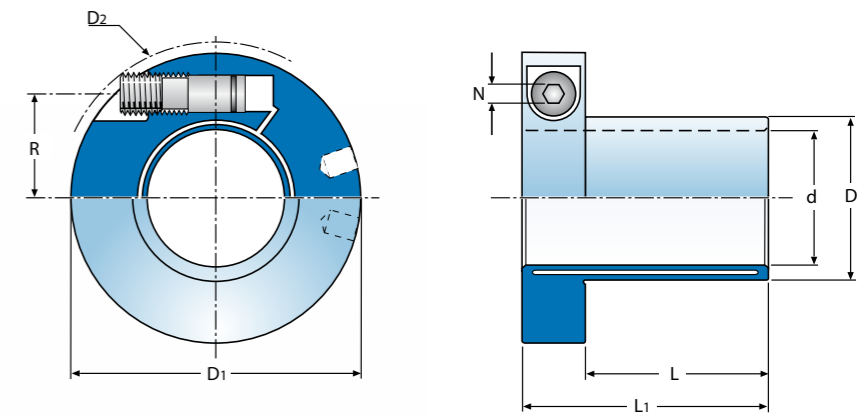
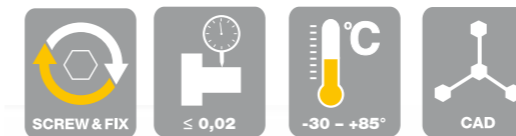
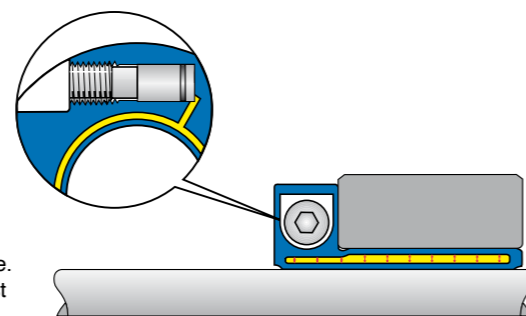

Notation: ETP-EXPRESS XXX

Technical specification ETP-EXPRESS®

ETP-EXPRESS®	Dimensions						Transmittable			Screws DIN 915, 12.9				Polar moment of inertia J kgm ² · 10 ⁻³	Weight kg
	d mm	D mm	D ₁ mm	D ₂ * mm	L mm	L ₁ mm	torque T Nm	axial force F _A kN	radial force F _R kN	Dim.	R mm	N mm	Tt Nm		
15	15	18	46	48,9	25	39	46	5,1	0,5	M10	15,1	5	5	0,04	0,16
5/8"	15,875	19	47	49,8	26	40	53	5,5	0,5	M10	15,6	5	5	0,05	0,17
19	19	23	50,5	53,0	28	42	85	7,3	1	M10	17,4	5	5	0,06	0,20
3/4"	19,05	23	50,5	53,0	28	42	85	7,3	1	M10	17,4	5	5	0,06	0,20
20	20	24	51,5	54,1	30	44	110	9,1	1	M10	18	5	5	0,07	0,21
22	22	27	55,5	60,5	32	46	130	9,6	1,2	M10	19,3	5	5	0,10	0,25
7/8"	22,225	27	55,5	60,5	32	46	130	9,6	1,2	M10	19,3	5	5	0,10	0,25
24	24	29	57,5	62,3	33	47	190	13	1,4	M10	20,3	5	5	0,11	0,27
25	25	30	58	62,9	35	49	230	15	1,5	M10	20,8	5	5	0,12	0,27
1"	25,4	31	59	63,8	35	49	190	12	1,5	M10	21,2	5	5	0,13	0,29
28	28	34	63	69,6	38	52	280	16	1,8	M10	22,6	5	5	0,17	0,34
1 1/8"	28,575	35	63,5	70,1	39	53	290	16	1,8	M10	23	5	5	0,18	0,35
30	30	36	64,5	71,0	40	54	380	21	2	M10	23,6	5	5	0,19	0,35
1 1/4"	31,75	39	68,5	77,7	42	56	430	22	2,2	M10	24,8	5	5	0,25	0,42
32	32	39	68,5	77,7	42	56	440	22	2,2	M10	24,8	5	5	0,25	0,42
1 3/8"	34,925	42	73	85,1	45	59	640	30	2,5	M10	26,4	5	5	0,32	0,48
35	35	42	73	85,1	45	59	640	30	2,5	M10	26,4	5	5	0,32	0,48
1 7/16"	36,5125	44	74,5	86,6	48	62	740	33	2,6	M10	27,3	5	5	0,36	0,52
38	38	46	84,5	89,5	52	72	890	38	2,8	M16	31	8	21	0,76	0,84
1 1/2"	38,1	46	84,5	89,5	52	72	890	38	2,8	M16	31	8	21	0,76	0,84
40	40	48	86,5	91,2	55	75	1100	45	3	M16	32	8	21	0,84	0,88
42	42	51	89	93,5	56	76	1100	43	3,2	M16	33,2	8	21	0,97	0,96
1 3/4"	44,45	54	93	100,3	58	78	1400	51	3,5	M16	34,8	8	21	1,20	1,10
45	45	54	93	100,3	58	78	1400	51	3,5	M16	34,8	8	21	1,17	1,05
48	48	59	97	103,8	59	79	1700	57	4	M16	36,8	8	21	1,46	1,21
1 15/16"	49,2125	60	98,5	105,1	60	80	1900	63	4,3	M16	37,5	8	21	1,57	1,27
50	50	60	98,5	105,1	60	80	1900	63	4,5	M16	37,5	8	21	1,52	1,20
2"	50,8	61	101,5	111,8	60	80	1900	62	4,5	M16	38	8	21	1,72	1,28
55	55	67	106	115,9	65	85	2400	71	5	M16	40,5	8	21	2,18	1,50
60	60	73	115,5	132,7	70	90	3300	90	5,3	M16	43,3	8	21	3,17	1,85
2 1/2"	63,5	77	119	134,6	73	93	4000	105	5,4	M16	45,1	8	21	3,74	2,04
65	65	79	120,5	137	75	95	4400	112	5,6	M16	46,1	8	21	4,1	2,13
70	70	85	135,5	153,9	85	109	5600	130	6,4	M20	50,8	10	39	7,12	3,04
3"	76,2	92	141,5	157,8	91	115	7500	160	7	M20	54,1	10	39	9,01	3,48
80	80	97	145,5	162,6	95	119	8700	180	7,5	M20	56,3	10	39	10,35	3,75
90	90	109	155,5	171,7	105	129	12000	220	8,6	2 x M20**	61,8	10	39	15,20	4,80
100	100	121	166	181,0	115	139	17000	280	9,7	2 x M20**	67,3	10	39	21,90	5,90

T= Transmittable torque when axial force is 0. } When the screw/screws is tightened to Tt
 F_A=Transmittable axial force when torque is 0.
 F_R=Max transmittable radial force at continuous operation.
 Max allowed bending torque: 5% of transmittable torque T.

Tt= Recommended tightening torque for the screw/screws. Further tightening does not increase the pressure.
 *) D2 is valid before mounting.
 **) Pressure screws positioned in the same direction. Dimensions subject to alterations without notice.

TOLERANCES

Shaft h7 for d = 15 mm.
 Shaft k6-h7 for d = 19, 22, 24, 28, 32, 38, 42, 48, 55 mm.
 Shaft h8 for all other dimensions d.
 Hub H7.

For further information see section Technical information/Design tips, page 52-55.

Type of torque

Transmittable torque, T, is for static load.
 If the load is alternating or pulsating torque, reduce the transmittable torque, T, with the following factors: (factor x T).
 Alternating: 0,5 x T.
 Pulsating: 0,6 x T.





Grasbeemd 21, 5705 DE Helmond, Nederland
Tel. +31 (0)492 594 300,
E-mail: pr@ammertech.nl, Internet: www.ammertech.nl



Box 1120, SE-581 11 Linköping, Sweden
Tel. +46 (0)13 24 71 00, Fax +46 (0)13 24 71 90
E-mail: info@etp.se, Internet: www.etp.se